

operating instructions

integrated amplifier EVOLUTION A3NG

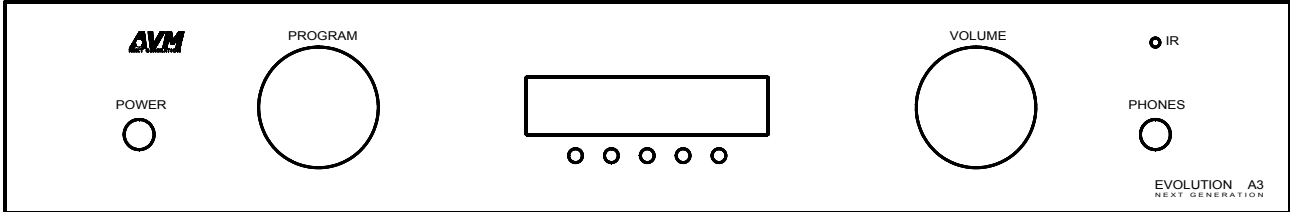

Dear customer,

thank You for purchasing this AVM product. You own now a versatile, excellent sounding hifi component. Before enjoying music, please read this manual carefully. After that You will know how to use Your new AVM component in the optimal way.

Sincerely Yours

Your AVM-Team

Declaration of conformity (for EC only)

We herewith confirm, that the unit to which this manual belongs fullfills the EC rules necessary to obtain the sign



the necessary measurements were taken with positive results.

**AVM Next Generation Audio Technologies GmbH, Daimlerstraße 8, D-76316 Malsch
Website: www.avm-audio.com, E-mail: info@avm-audio.com**

Table of contents

	page
Präamble	2
Table of contents	3
1. Basic informations	4
1.1 Mechanical construction	4
1.2 Preamplifier	4
1.3 Poweramplifier	4
1.4 Tuner (option)	5
1.5 Phono (option)	5
2. Control elements and connectors	6
2.1 EVOLUTION A3NG overview	6
2.2 Connectors	7
2.3 Insertion and removal of plug-in cards	7
2.4 Setting of the phono card	8
2.5 Installation and cooling	9
2.6 Connection to mains	9
2.7 Connecting the signal sources	9
2.8 Connecting a tape recorder	9
2.9 Connecting processors and equalizers	9
2.10 Connecting loudspeakers	9
2.10.1 Bi amping	10
2.10.2 Connecting the additional poweramps	10
2.10.3 Trigger outputs	10
2.11 Connecting subwoofers	11
2.11.1 Passive subwoofers	11
2.11.2 Active subwoofers	11
2.11.2 Active subwoofers with built in filters	11
2.12 Headphones	11
2.13 Antenna connection	11
2.14 Connection of a turntable	11
3. Basic operation	12
3.1 First connection to mains	12
3.1 Switching on / standby	12
3.2 Selecting the signal source	12
3.3 Volume setting	12
3.4 Setting of input sensitivity	12
3.5 Tuner (option)	13
3.5.1 Tuning	13
3.5.2 Station memory	13
4. Advanced settings, the menu system	14
4.1 Tuner mode DAB / FM	14
4.2 RDS-Display	14
4.3 Scanmode	14
4.4 Mode	14
4.5 DAB antenna	14
4.6 FM antenna	14
4.7 Tone	15
4.8 Bass	15
4.9 Treble	15
4.10 Loudness	15
4.11 Balance	15
4.12 Name	15
4.13 Processor	15
4.14 Monitor	15
5. Remote control (option)	16
6. Cleaning	16
7. If something doesn't work	16
8. Conditions of warranty (EC only)	17
9. Technical data EVOLUTION A3NG	18
10. Appendix 10.1 EXPERT SETUP, 10.2 RESET	19

1. Basic information about the A3NG

1.1 Mechanical construction

The case is fully made of steel. This material acts as a shield and protects drive and circuitry against interferences from external magnetical and electrical fields. The audio-connectors are all gold plated to minimize electrical losses and provide long lasting perfect contacts.

1.2 Preamplifier

A toroidal transformer together with 10.000 μ F of capacitance supplies the power for the preamplifier and the control and display circuits. All voltages are well regulated to avoid hum and are additionally buffered by large capacitors directly in the circuitry where they are needed.

The A3NG has a balanced XLR input as well as 3 RCA Cinch inputs and a tape in / out with monitor function. A processor in / out connector allows you to connect an equalizer or an active subwoofer easily. Additionally you can install an universal phono pcb for MM as well as MC pickups (option), a FM-/DAB tuner pcb (option) and later we will offer a pcb with 2 digital inputs. A processor in / out connector allows you to connect an active subwoofer easily.

The active input signal is selected by a semiconductor switch. Directly behind this switch the signal is buffered by a very fast amplifier with excellent S/N ratio and very low output impedance.

The volume control is done by a highly precise integrated circuit. It allows setting in 0,5 dB steps and the channel balance is better than 0,05 dB. All this provides an absolutely precise, musical sound reproduction from lowest to highest listening levels.

If you wish to set the frequency response at low listening levels (loudness) or to have more or less treble or bass, you can activate the sound processor and set the frequency response. For linear reproduction the whole circuitry is removed out of the signal path by relays with gold plated contacts and has absolutely no influence.

The preamp's output circuitry uses discrete output transistors together with a highly precise opamp driver stage. The powerful output transistors offer an output impedance of 75 Ohms (RCA cinch) and work down to 75 Ohms load in class-A-mode. Thanks to the low output impedance they can drive any cable regardless of capacitance without loss in sound quality.

The level at the preamp outputs matches perfectly with the M3NG mono amplifiers. So if you wish to operate the A3NG in biamping mode just connect a pair of M3NG to the A3NG's pre out and the bass input of your loudspeakers, the A3NG's speaker outputs to the mid & tweeter inputs and enjoy!

1.3 Poweramplifier

The power amplifier has it's own power supply. A powerful toroidal transformer which can deliver 225 Watts continuously and up to 450 Watts for a short period of time supplies exclusively the energy for the poweramp.

High bandwidth, low distortion, low noise and a high damping factor were the aims when the A3NG's poweramplifier was developed. Of course the circuitry had to be safe against external short circuits and overheat. For the A3NG we found an integrated circuit which offers all these features ideally combined. The A3NG uses two of these circuits per channel. Thus it can easily supply the necessary current even for low impedant loudspeakers.

A discrete input stage using field effect transistors (FET) receives and decouples the music signal from the preamp section. These transistors act similar to tube amplifiers and add a small portion of harmonics to the signal. This is why the A3NG sounds warm and musical.

1.4 Tuner (option)

The tuner pcb is installed in a slot in the rear panel of the A3NG. It can receive FM as well as DAB. Therefore it has two antenna sockets. In FM mode it offers optimal sound quality from aerial antenna as well as from cable. With it's high sensitivity the tuner can also work with a simple indoor antenna. For DAB reception we recommend the use of a special DAB antenna (ask your local dealer).

The stereo decoder offers high channel separation as well as very low noise.

The RDS section (audio data system, not available in all countries) is processor controlled and shows station names and texts with additional information about the program you are listening to.

The station memory can store up to 50 stations. It stores not only their frequency, but also the individual setting of mode (mono/stereo).

1.5 Phono (option)

The phono pcb is also installed in a slot in the rear panel of the A3NG. You can connect MC pickups as well as MM-types. The phono pcb is very versatile and allows individual setting of cartridge type, cartridge load and gain. The RIAA-equalization uses precise film capacitors and has a built in subsonic filter. So it works well with most of all cartridges on the market.

2. Control elements and connectors

2.1 EVOLUTION A3NG overview

The numbers in the drawings below mark the control elements. They refer to the numbers in the text, where the operation of the A3NG is described.

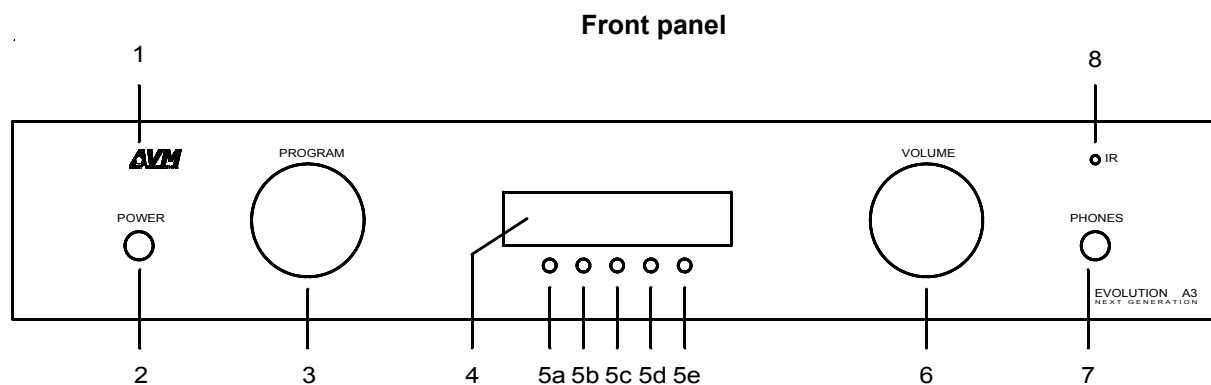

- | | |
|------------------------------------|---------------------------------------|
| 1 LED (lights up, when unit is on) | 5 Multifunctional buttons (soft keys) |
| 2 Button power (on / standby) | 6 Volume knob |
| 3 Input selector | 7 Phones jack |
| 4 Display | 8 IR-Receiver |

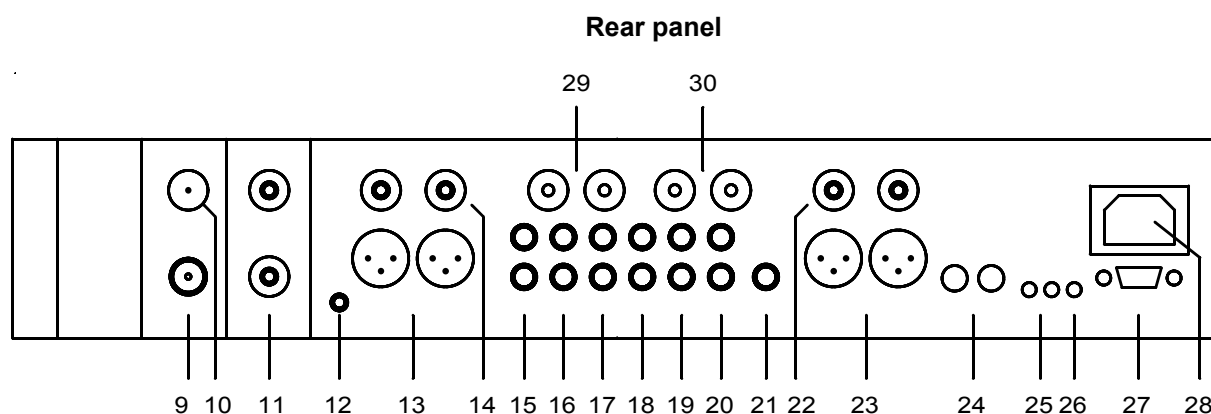

- | | |
|---|--|
| 9 Antenna socket DAB (Option) | 21 Mono output |
| 10 Antenna socket FM (Option) | 22 Pre out 1 (RCA Cinch) |
| 11 Phono input (Option) | 23 Pre out 2 (balanced XLR) |
| 12 Ground connector for turntable chassis | 24 Trigger outputs |
| 13 Input 1 (balanced XLR) | 25 Interface (for future use) |
| 14 Input 2 | 26 Connector for external infrared signal |
| 15 Input 3 | 27 Serial interface (for future use) |
| 16 Input 4 | 28 Mains connector |
| 17 Input tape | 29 Speaker output right channel
(red = live, black = GND) |
| 18 Record out | 30 Speaker output left channel
(red = live, black = GND) |
| 19 Processor output | |
| 20 Processor input | |

2.2 Connectors

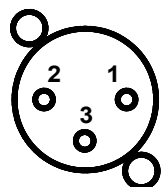

balanced XLR input

- 1 = GND (shield)
- 2 = non inverting input
- 3 = inverting input

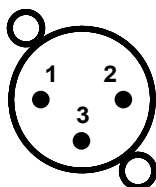

balanced XLR output

- 1 = GND (shield)
- 2 = non inverting output
- 3 = inverting output



trigger output

- a = GND
- b = Trigger signal

2.3 Insertion and removal of plug-in cards

CAUTION: Before installing or removing cards ensure that the power plug is disconnected. Printed circuit boards are never to be installed or removed with the unit switched on. If you are inexperienced in working with electrical appliances it is recommended that you request your dealer to install the plug-in cards.

Currently we offer two plug in cards for the A3NG: A tuner card and a phono input. A digital in / out will be offered in the future. For these cards the A3NG has 3 slots on the rear panel:

- The (seen from the rear side) most right is for phono
- The place in the middle is for tuner
- The (seen from the rear side) most left is for digital I/O (currently not available)

The cover plates are each secured to the housing with a screw above and below. Before removing a cover plate, unscrew both screws entirely. The cover plate (cover plates are marked "PHONO", "TUNER", "DIG I/O") can now be removed.

Rotate the card that is to be installed in such a way that the components are on the left side. Insert the new card into the free slot. Ensure that the plug of the circuit board mates with the relevant socket inside the unit. Push the card firmly home but do not use force. At the end of the procedure the rear face of the card must be in level with the other rear surfaces. After the two securing screws have been firmly replaced you A3NG is ready for operation.

NOTE: The plugs of the circuit boards are mounted different heights. This ensures that a phono card doesn't fit into the slot where the tuner must be installed and vice versa. So please make sure to install each card in the right slot and do not use force when pushing the card into the A3NG.

2.4 Setting of the phono card (option)

To ensure that the phono card works in an optimal way, it must be set according to the requirements of the cartridge. Please refer to the operating manual / technical data of your cartridge to find out the correct settings. The setting is done by switches on the pcb. The upper switches are for the right channel, the lower for the left channel. The switches for both channels must be set identically.

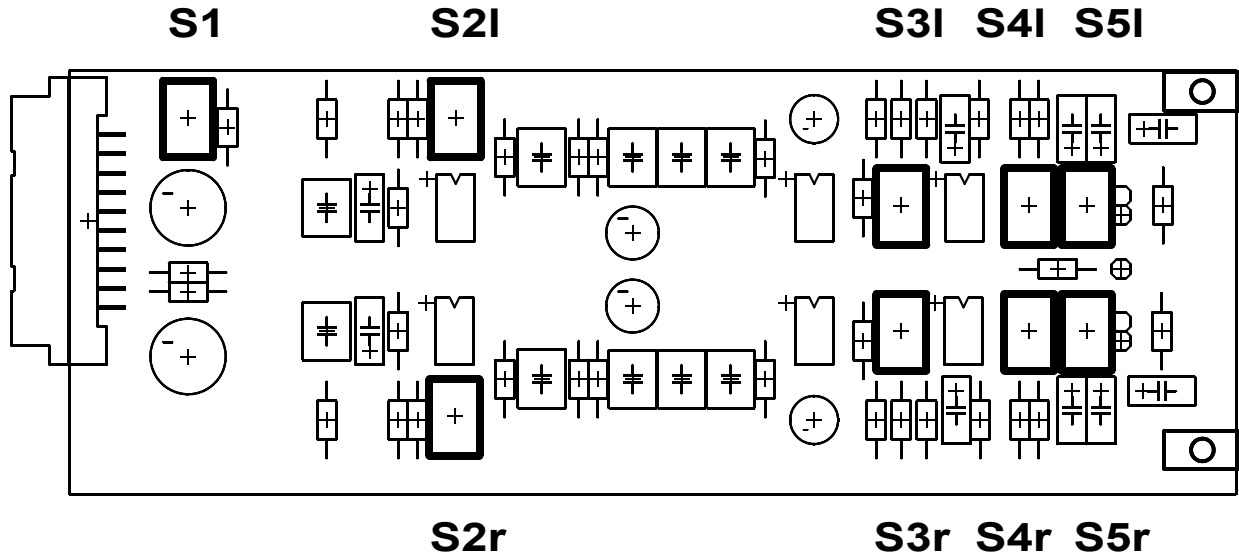

		S1/1+2	S2/1	S2/2	S3/1	S3/2	S4/1	S4/2	S5/1	S5/2
MM-cartridges		OFF			OFF	OFF	OFF	OFF		
Output voltage	< 1 mV		ON	ON						
	1 mV – 2,5 mV		OFF	ON						
	2,5 mV - 5 mV		ON	OFF						
	> 5 mV		OFF	OFF						
Load capacitance	up to 200 pF								OFF	OFF
	200 - 350 pF								ON	OFF
	350 - 450 pF								OFF	ON
	450 - 600 pF								ON	ON
		S1/1+2	S2/1	S2/2	S3/1	S3/2	S4/1	S4/2	S5/1	S5/2
MC-cartridges		ON			ON	ON			OFF	OFF
Output voltage	< 100 µV		ON	ON						
	100 µV - 250 µV		OFF	ON						
	250 µV - 500 µV		ON	OFF						
	> 500 µV		OFF	OFF						
Load resistance	25 - 75 Ohms						ON	ON		
	75 - 150 Ohms						ON	OFF		
	150 - 500 Ohms						OFF	ON		
	> 500 Ohms						OFF	OFF		

2.5 Installation and cooling

The A3NG can become hot depending on demanded output power and environmental temperature. Therefore it is important, that the cooling air can flow unhinderedly into the air inlet in the A3NG's bottom and flow out through the holes in the cover.

Additionally direct exposure to sunlight is not recommended because this will heat up the unit.

2.6 Connection to mains

Connect the A3NG to the mains outlet by using the power cord which is (in some countries) delivered together with the unit. Make sure that mains voltage is according to the value printed on the rear panel of the amp (near mains connector (28)).

Let the unit be switched off until all audio connections are made.

2.7 Connecting the signal sources

Connect the outputs of your signal sources to the inputs (13 - 16). The upper row of the RCA cinch connectors is for left channel, the lower row is for right channel. The inputs tape (17, 18) and processor (19, 20) provide special functions, which are described below.

If Your A3NG is equipped with a built in phono preamplifier (option, see chapter 5), connect the output of Your turntable with inputs 2 (14) and connect the chassis ground wire to the A3NG's ground connector (13).

2.8 Connecting a tape recorder

Connect the recorder's output to the inputs tape in (17). The inputs of the recorder must be connected to the outputs tape out (18).

2.9 Connecting processors / equalizers

Connect the processor's outputs to the inputs proc in (20). The inputs of the processor must be connected to the outputs proc out (19). If you use an active subwoofer please refer to chapter 2.11

2.10 Connecting loudspeakers

Connect the speakers to the speaker terminals (29, 30) of the a6. Use only good speaker cables with sufficient diameter. Make sure, that the red terminals are connected to the red or " + " terminals of the speakers and the black terminals to the black or " - " terminals of the speakers.

NOTE: The speaker cables must have 4mm banana plugs. If your cable do not have plugs we recommend the WBT banana plug type 0645. Which can be connected to most cables and offers optimal sound quality.

2.10.1 Bi amping

Many loudspeakers have bi-amping terminals. That means that the bass and the mid / hi range chassis can be connected independently to two amplifiers (bi amping). For the A3NG we recommend the use of a pair of our mono amplifiers M3NG for the bass and the A3NG's built in poweramplifier for mid an treble range.

The M3NG match ideally with the A3NG. They offer the same warm music reproduction as the A3NG. In combination with the A3NG the sound image will be even clearer and the dynamic range is dramatically increased.

2.10.2 Connecting the additional poweramps

The gain factor of the M3NG is the same as for the A3NG. So you can simply connect them to the A3NG's preamp outputs (22, 23). Then connect the power outputs of the M3NGs to the bass terminals of your speakers and the A3NG's power outputs (29, 30) to the mid / treble terminals.

CAUTION: Do not forget to remove the bridges between these two inlets at the loudspeaker terminals. Otherwise the A3NG or the M3NG could be damaged.

2.10.3 Trigger outputs

Connect the A3NG's trigger outputs (24) to the trigger inputs of the additional poweramp or (if connected) the subwoofer. Then these units will automatically switch on and off together with the A3NG. The pinning of the trigger outputs is described in chapter 2.2.3.

2.11 Connecting subwoofers

2.11.1 Passive subwoofers

Together with a passive subwoofer you need a mono power amplifier. The input of this amplifier is connected to the A3NG's mono output (21). The power amplifier's output must be connected to the subwoofer. The gain of the power amplifier must be adjustable so that you can match the sound level of the stereo speakers with that of the subwoofer.

The A3NG has a built in subsonic filter (see chapter 10.1, EXPERT 17/21). When this filter is activated the stereo speakers are protected from unwanted subsonic signals (which are exclusively reproduced by the subwoofer).

2.11.2 Active subwoofers

If you use an active subwoofer (with built in power amplifier), simply connect it's input to the A3NG's mono output and adjust the bass level at the subwoofer. If the subwoofer has a trigger input, connect it to the A3NG's trigger output (24, see also chapter 2.10.3).

2.11.3 Active subwoofers with built in filters

Most active subwoofers have a built in frequency divider network. They receive the full range signal from the amplifier and feed the filtered signal (full range minus bass) back. This kind of subwoofer can be connected to the A3NG's processor in / output: Connect the subwoofer's inputs to the A3NG's processor outputs (19) and the subwoofer's outputs to the A3NG's processor inputs (20). Now activate the A3NG's processor function (see chapter 4.13).

If the subwoofer has a trigger input, connect it to the A3NG's trigger output (24, see also chapter 2.10.3).

2.12 Headphones

Plug the 6,3mm headphones to the A3NG's headphone jack (7). The loudspeaker and preamp outputs will mute automatically when the plug is in.

2.13 Antenna connection (if optional tuner is installed)

Connect the Antenna cable to the antenna socket (FM: 10 / DAB: 11) of the A3NG.

NOTE: DAB is not available everywhere. DAB reception requires use of a special antenna. For more information please contact your dealer.

2.14 Connection of a turntable (if optional phono card is installed)

Connect the signal cables of the turntable to the A3NG's phono inputs (9). The grounding cable coming from the turntable's chassis must be connected to the A3NG's GND connector (12). Use a 4 mm banana plug.

NOTE: For optimal sound quality you must adjust the parameters of the phono card according to the requirements of the cartridge (see chapter 2.4).

3. Basic operation

3.1 First connection to mains

When the A3NG is connected to mains for the first time the unit checks its configuration and if all installed components work properly. If a Tuner is installed and the DAB-function is activated, the unit will scan the DAB band in order to identify the available DAB stations. This will last about 1 minute. The procedure is shown in the display (4).

3.1 Switching on / standby

Using the button power (2) You can switch between on (operate) and stand by. In the on state the display (4) and the LED (1) light up. In stand by mode the display is off and the LED glows to indicate that the unit is still connected to mains.

CAUTION: When switched to stand by the unit is still connected to mains. In case of thunderstorm or if You leave the house for a longer time we recommend that You pull the mains plug.

3.2 Selecting the signal source

Use the program selector (3) to select a signal source. The selected source is indicated in the display (4).

3.3 Volume setting

Use the rotary encoder (6) to set the desired volume. Depending on rotating speed the volume increases / decreases in 0,5 dB steps (slow) or 3 dB steps (fast). The actual setting is shown in the display (4).

3.4 Setting of input sensitivity

The level of signal sources differs often by several dB. So You recognize a step in volume, when switching between two inputs. It is also possible, that a source which is too loud overdrives the input and causes distortion. With the sensitivity setting menu You can avoid this. The sensitivity of each input can be set between – 12.5 dB and + 12.5 dB.

NOTE: The input level of the internal tuner (if build in) is fixed and cannot be changed.

Select an input with the program selector (3) and chose a convenient volume level. Now press the button MENU (under the display) for more than 2 seconds. The display (4) now shows "level". In the upper line it shows the name of the actual source and on the right side the actual input sensitivity (factory setting: "0,0"). Set the sensitivity using the buttons ◀ VALUE ▶ (5d, 5e). Switching between the several sources allows You to compare and adjust the levels. If You are ready, press EXIT (5c) and Your settings are stored.

3.5 Tuner (option)

The tuner can be selected using the program selector (3). The basic functions of the tuner can then be accessed by the buttons right under the display (5). For more sophisticated functions see chapter 4.

3.5.1 Tuning

FM: Depending on the selected mode (manual / auto) the most right buttons (5d, 5e) under the display (4) are named ◀ AUT ▶ or ◀ MAN ▶. In auto mode a tip on one of the buttons lets the tuner automatically seek the next upper or lower station. In manual mode the frequency changes in 50 kHz-steps as long as the button is pressed.

DAB: The DAB radio stations are organized in "Ensembles". Therefore manual tuning is not possible. The buttons ◀ AUT ▶ can be used to access the next or previous available DAB radio station.

NOTE: The DAB function must be activated before use. See chapter 10, EXPERT 10/21.

3.5.2 Station memory

If You want to store a certain station in the memory, press the button MENU (5c) under the display (4) for more than 2 seconds. The display shows now on the left side the number of the actual memory position. It can be changed by pressing the buttons below (5a, 5b). On the right side You can see the frequency of the station which is actually stored in this memory position (if none: "unused") and below the frequency of the new station to be stored.

Press SAVE (5e) to store the actual station, EXIT (5c) to cancel the procedure or DELETE (5f) if You want to delete the stored station.

NOTE: The station memory allows You to store up to 50 stations. It stores not only their frequency, but also the individual setting of mode (mono/stereo). You can store FM and DAB stations in mixed sequence.

◀ PGM ▶ (4, 5) selects the stations stored in the memory. A short tip switches to the next / previous station. Holding the button down scans automatically up / down. The number of the actual station is shown in the display.

4. Advanced settings, the menu system

The A3NG offers a lot of custom specific settings in its menu system. To enter the menu just tip on the button MENU (5c). The button now changes to EXIT. A second tip on this button leads You to the normal operating mode. When the menu system is active You can select the desired function using the parameter-buttons ◀ PARM ▶ (5a, 5b). The setting is done using the buttons ◀ VALUE ▶ (5e, 5f).

Depending on the actual source the menu system offers the following settings:

4.1 Tuner mode DAB / FM (tuner must be selected as source)

Choose the reception mode. This setting is only accessible if the DAB function is activated. See chapter 10, EXPERT 10/21.

4.2 RDS-Display (tuner must be selected as source)

Choose if station name ("station") or RDS text ("text") is displayed.

4.3 Scanmode (tuner must be selected as source)

Set tuning mode between "auto" or "manual". Depending on the selected mode (manual / auto) the most right buttons (5d, 5e) under the display (4) are named ◀ AUT ▶ or ◀ MAN ▶. In auto mode a tip on one of the buttons lets the tuner automatically seek the next upper or lower station. In manual mode the frequency changes in 50 kHz-steps as long as the button is pressed. This setting is only accessible in FM mode

4.4 Mode (tuner must be selected as source)

Set tuner to mono or stereo to obtain best sound. This setting is only accessible in FM mode

4.5 DAB antenna (tuner must be selected as source)

Select the antenna socket used for DAB: "1" = lower socket (11, default), "2" = upper socket (10). This setting is only accessible if the DAB function is activated. See chapter 10, EXPERT 10/21.

4.6 FM antenna (tuner must be selected as source)

Select the antenna socket used for FM: "1" = lower socket (11), "2" = upper socket (10, default). This setting is only accessible if the DAB function is activated. See chapter 10, EXPERT 10/21.

4.7 Tone

Set tone control to "bypass" (= linear) or "active". In case the tone control is activated a note symbol is shown in the display (4).

4.8 Bass

Set bass level between -10 and + 18.

4.9 Treble

Set treble level between -14 and + 14.

4.10 Loudness

If You listen to music at low levels, You often recognize that bass and treble reproduction are weak. This is because the human ear is not sensitive to bass and treble at low sound levels. To compensate this You can use the parametric loudness function of the A3NG. This function will increase bass and treble levels when You decrease the volume. When the volume is increased the frequency response will be more and more flat and remain linear at high volume levels. In order to obtain best results You have to proceed as follows:

Set the amplifier to a moderate volume level. Using the buttons ◀ VALUE ▶ (5d, 5e) choose in the loudness menu a curve ("off" to 9) which gives best sound impression and exit the menu (button EXIT (5c)).

NOTE: The loudness function selects automatically the correct curve depending on actual volume setting. So if You change volume a different curve than previously selected may be shown if you access the loudness menu anew. This is not a malfunction.

4.11 Balance

Set the balance between right and left channel for optimal stereo image.

4.12 Name

You can individually set the names (max. 8 characters) of the different sources shown in the display (4). Enter the "NAME" menu and press one of the buttons ◀ VALUE ▶ (5d, 5e). Now You are in the edit mode. The source is selected using the program selector (3). The actual character-position can be selected using the buttons ◀ POS ▶ (5a, 5b). The marked character (underlined) can be changed using the buttons ◀ VALUE ▶ (5d, 5e).

When You are ready, simply press EXIT (5c). and the new names are stored.

4.13 Processor

Switches processor function "on" / "off". If the processor is activated, it influences the signals on the speaker outputs. The signals on record out are not affected. The display (3) shows "PROC" in the upper line while the processor function is activated. See also chapter 2.9 and 2.11

4.14 Monitor

Switches tape monitor function "on" / "off". If the monitor is activated, the display (3) shows a tape symbol.

NOTE: The A3NG has an "intelligent" monitor function. If the tape input is selected as source the monitor function is cancelled to avoid feedback from the tape recorder.

TIP: To access the monitor function quickly, press the MENU button (5c) and then once the button ◀ PARM. (5a). Now You can switch the monitor function on and off using the buttons ◀ VALUE ▶ (5d, 5e).

5. Remote control (option)

As accessories we offer different infrared remote control transmitters. Ask your dealer.

6. Cleaning

Use a soft cloth and normal glass cleansing fluid.

CAUTION: Make sure that no fluid comes into the unit. Do not use scouring cleaners. They may damage the surface.

7. If something doesn't work.....

Some putative defects are often caused by mistakes in operation. Sometimes other units connected to the unit can cause problems. Therefore please read the following tips before You consult Your dealer or us.

No Sound

- The monitor function is activated. Switch monitor off (see chapter 4.14)
- The processor function is activated. Switch monitor off (see chapter 4.13)
- The unit has unwantedly been set to standby by remote control. Push the power button (2)

Hum while playing records

- Connect the grounding cable of the turntable's chassis to the A3NG's GND connector (12)

No RDS display in tuner mode

- The RF level of the received station is too low.
- Some radio stations do not transmit RDS signals

Infrared remote control doesn't work

Check the batteries of your remote control transmitter

Point with the remote control transmitter directly to the unit.

8. Conditions of warranty (EC only)

If despite expectations a defect occurs that cannot be repaired by yourself or your dealer, we undertake the repair of your unit free of charge for up to two years from date of purchase. The warranty covers the costs of material and working time, transport costs are to be borne by the owner.

Provisions for this warranty are:

- The unit must have been purchased from an authorized dealer. Equipment from other sources will not be repaired, not even at charge.
- The warranty registration card, together with a copy of the bill of sale, must be received by us within four weeks of the date of purchase.
- The defect must not have been caused by improper handling or misuse.
- Return the unit to us only in its original packing. If this is not possible we are entitled to refuse acceptance. We will not assume responsibility for transport damage under any circumstances.
- A short description of the defect is to be included with the returned unit.
- In cases of doubt we reserve the right to request a copy of the bill of sale.
- We also reserve the right to levy a handling charge for items returned without good or valid reason, or if the unit proves to be not defective.

NOTE

If you are returning the unit from a country other than Germany you should ensure that correct export documents are obtained. We cannot accept any charges for costs arising from improper or incomplete export documentation.

If you have purchased your unit from a dealer outside Germany please refer to him or the relevant importing firm to process the warranty.

9. Technical data EVOLUTION A3NG

Amplifier

Sensitivity (25 W/4 Ohm)	20 mV – 350 mV (adjustable)
Input impedance balanced XLR	10 kOhms
Input impedance RCA Cinch	6,8 kOhms
Input impedance processor	4,7 kOhms
S/N	97 dB / 100 dB(A)
Frequency response	< 5 Hz - > 200 kHz
Phono equalization	according to RIAA +/- 0,5 dB (Option)
THD (25 W/4 Ohm)	< 0,08%
Rise time	1,6 µs
Damping factor	>300
Output power	70 W (8 Ohms) / 100 W (4 Ohms)

Tuner (option)

FM

Frequency range	87,5 MHz – 108,0 MHz
Step	50 kHz
Antenna impedance	50 Ohms
Sensitivity mono / stereo	1,5 µV / 50 µV
S/N mono / stereo	73 dB(A) / 68 dB(A)
THD mono / stereo	0,1% / 0,5%
Frequency response	30 Hz – 16 kHz
Channel separation	55 dB

DAB

Frequency range	174 MHz – 240 MHz (Band III), 1452 – 1492 MHz (L-Band)
Antenna impedance	50 Ohm
Sensitivity	-98 dBm
Step	16 kHz
THD	0,1% (depends on transmitted data rate)
Frequency response	30 Hz – 20 kHz (depends on transmitted data rate)
Channel separation	85 dB (depends on transmitted data rate)

Power consumption

Standby	1 W
max.	250 W
Power supply	AC 230V / 50-60Hz
(Upon request	AC 115 V / 50-60 Hz)
Dimensions (W x H x D)	430 x 85 x 340 mm
Weight	9 kgs

Issued: 12/2007. Changes reserved without notice

10 Appendix

10.1 Expert setup

Several settings can be done in the expert setup. After having done that you can block these settings in the normal menu. This simplifies the operation of the A3NG for the enduser.

To access the expert setup switch the unit to standby (power button (2)). Then press and hold the most right key under the display (5f). While holding that key switch the unit on (power button (2)). The display now will show a count down "expert setup in 5, 4, 3, 2, 1 sec". After that count down release the button (5f) and the unit is in expert setup mode. If you wish to exit the setup press "EXIT" (5c).

When the expert setup is active You can select the desired function using the parameter-buttons ◀ PARM ▶ (5a, 5b). The setting is done using the buttons ◀ VALUE ▶ (5e, 5f).

The display (3) shows in the upper line the active setup point (for example "EXPERT 4/21") and below the possible setting.

EXPERT 1/21:	Deactivate the processor menu (4.13)
EXPERT 2/21:	Deactivate the monitor menu (4.14)
EXPERT 3/21:	Deactivate the sound setting menu (4.7 - 4.10)
EXPERT 4/21:	Deactivate the balance menu (4.11)
EXPERT 5/21:	Deactivate the source name menu (4.12)
EXPERT 6/21:	Deactivate the level menu (3.4.1)
EXPERT 7/21:	Setting of duration of volume display, when tuner is active and volume changed.
EXPERT 8/21:	Deactivate the tuner mode menu (4.4)
EXPERT 9/21:	Deactivate the station memory menu (3.5.2)
EXPERT 10/21:	Deactivate / activate the DAB tuner. Deactivation makes sense if there is no DAB reception possible. This avoids that the A3NG makes a (useless) DAB scan every time the unit is connected to mains.
EXPERT 11/21:	Setting of tuner deemphasis (50 µs for Europe, overseas sometimes 75 µs)
EXPERT 12/21 - 16/21:	Deactivate unused inputs. The A3NG will then skip these inputs when the source Selector is rotated.
EXPERT 17/21:	Deactivate / activate the subsonic filter. (Activation makes sense if the A3NG operates together with a subwoofer.
EXPERT 18/21:	"yes" enables individual tone control per source.
EXPERT 19/21 -21/21:	If tone per source is enabled you can set the tone control individually for each input. If not you can set the tone controls generally for all inputs. Use the input selector (3) to select sources. And the volume knob to set volume.

10.2 Reset

This function cancels all settings and makes the unit return to default settings.

To perform the reset switch the unit to standby (power button (2)). Then press and hold the middle key under the display (5c). While holding that key switch the unit on (power button (2)). The display now will show a count down "reset in 5, 4, 3, 2, 1 sec". After that count down release the button (5c) and the unit performs the reset. If you release the button (5c) earlier the reset is cancelled.